

Deckel / Lid

* = Mass durch Formkonizität nach unten verringert.
 Freimass - Toleranz nach GTA 13/5 - DIN 1688
 * = Dimensions reduced in the lower part by mould incline
 General tolerances according to GTA 13/5 - DIN 1688

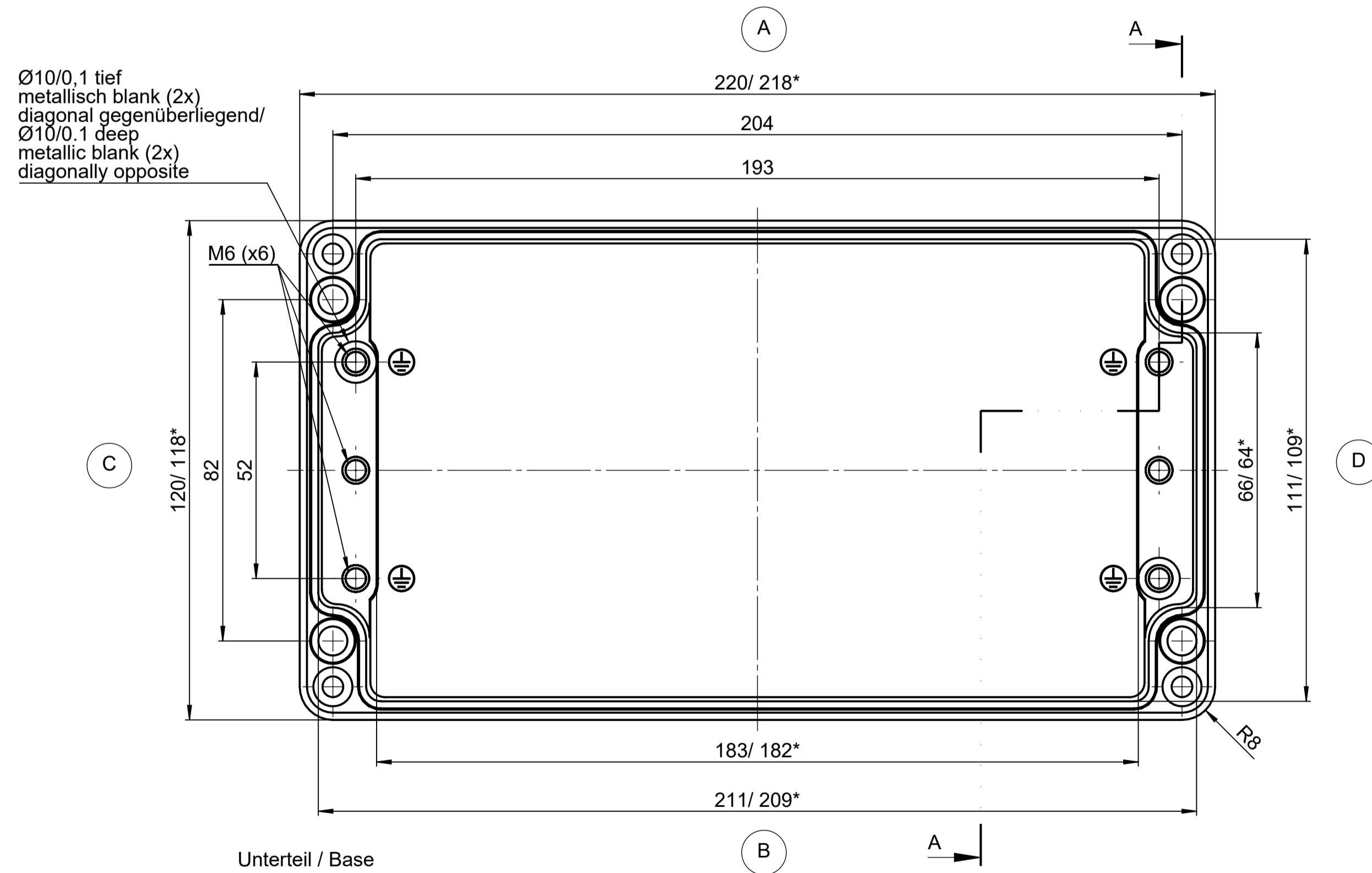

Unterteil / Base

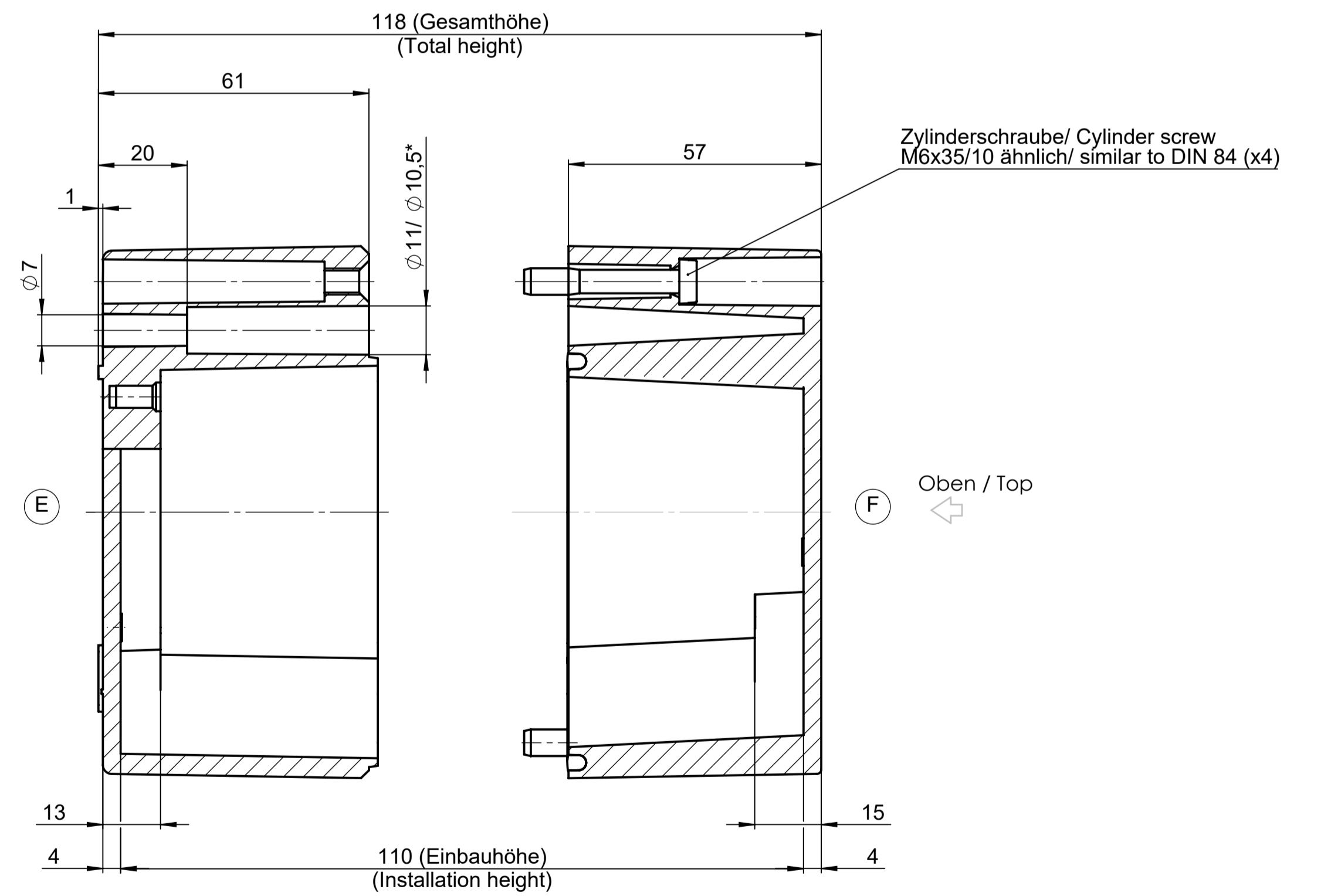

Projekt-Nr./project-no.		Farbe/color		Gewicht/weight		2.00kg	
Index	Änderung/Modification	Änd.Nr./Mod.Nr.	Datum/Date/Name	Werkstoff/Material			
				Oberfläche/Surface			
erstellt: created: geprüft: checked:				Freimass/Tolerance	DIN 1688-GTA 13/5		
Bemerkung/Note Aluminium Gehäuse Aluminium enclosure				Ersatz für Replacement for Zeichnung-Nr./Drawing-No.:			
Maßstab Scale 1:1 DIN A1				GBA220120118			